

Introduction

As energy prices continue to rise, farmers must reduce electricity and fuel use on the farm in order to reduce operation costs. Many energy conservation measures are free, low-cost, or have a cost-effective payback. This publication provides an overview of energy conservation across the many operations of the average dairy farm in Massachusetts. After reading this, the next step is to use a farm energy calculator as a self assessment tool to determine where energy inefficiencies are occurring on your farm and where improvements can be made. Next, conduct an energy audit of your farm. Many utility companies can recommend an auditor or audit information can be found through the Massachusetts Farm Energy Program (MFEP) or the USDA Rural Energy for America Program (REAP). Finally, take advantage of state and federal tax breaks, grants, and incentive programs for reducing energy use on your farm (Additional information below).

Steps to Energy Efficiency:

1. Read this publication
2. Use an energy calculator to determine current energy use.
3. Conduct an Energy Audit.
4. Target energy saving projects and practices to implement on the farm.
5. Seek Funding.
6. Implement your energy conservation plan.
7. Perform regular maintenance on machinery to ensure efficient and long lasting performance.

Tips for Reducing Energy Use

Tractors, field work, grain driers, buildings, watering systems, fences, and other farm equipment are all part of daily operations on a modern dairy farm and can incur high costs in energy use. The two main types of energy use on farms are electricity from the local utility company and fuel such as heating oil or diesel for running farm equipment. The following pages offer simple ways to improve energy efficiency on the farm.

Tractors and Vehicles

Equipment driven on fields is one of the largest uses of energy on the farm, so careful maintenance and use of tractors will improve energy efficiency greatly. Ultra low sulfur diesel (ULSD) fuel has been phased in over the past few years. Reducing sulfur has allowed for reduction in emissions. However, as with the removal of lead from gasoline many years ago, problems can surface in older equipment. Whether or not additives improve lubrication is disputed. The other problem that occurs is gasket leakage as a result of a change in fuel. Replacing gaskets will solve the problem. Keeping engines running well in the winter with electric warmers is cheaper than using fuel to heat the engine. Idling vehicles can use up to 20% of total fuel use, so turn off machinery when not in use. If there are fuel tanks on the farm, keep them cool to reduce evaporation of fuels, and regularly inspect for leaks.

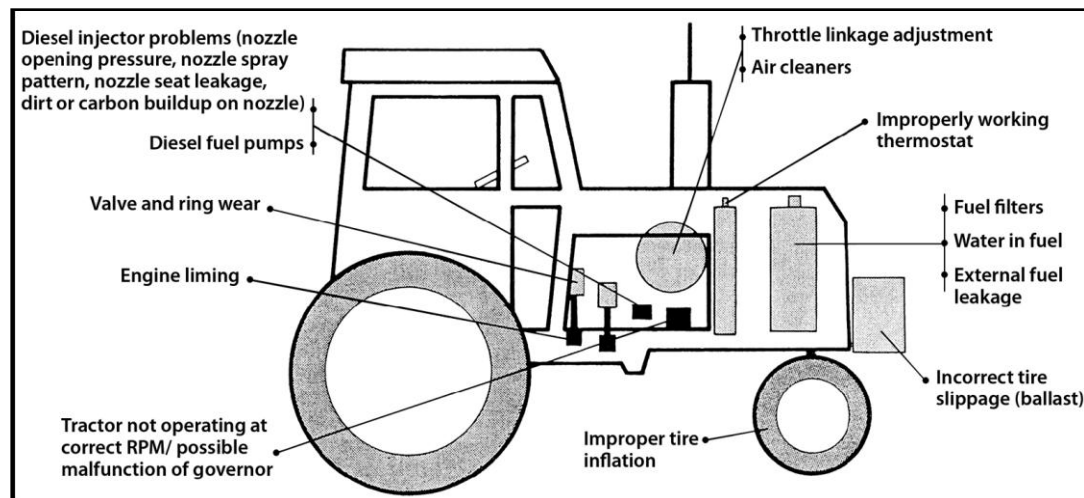

Figure 1. Factors reducing fuel efficiency on a diesel tractor
<http://attra.ncat.org/attra-pub/PDF/consfuelfarm.pdf>

Regular maintenance of farm machinery including tune-ups, replacing filters, changing oil, and keeping tires inflated and balanced will help machinery last longer and save fuel. Remove unnecessary weight from vehicles to reduce fuel use. Use an appropriately sized tool or machine for the job so as not to waste fuel. Too much or too little horsepower will reduce fuel efficiency. Drive tractors in higher gears and at lower rpm or throttle setting to reduce fuel use but not so slow as to produce black smoke or a sluggish response. Sharpen ground tillage implements to work the soil with less resistance. Consider purchasing an ATV so as not to use a full sized truck for some smaller on-farm tasks.

Field Practices: Switching to no-till or minimum tillage can reduce fuel use by 86% but may increase the farmer’s dependency on herbicides to control weeds. Several conservation tillage methods exist such as zone or strip tillage where only the seeding area is plowed, or ridge and mulch till which require fewer trips across the field. Combining field tasks such as spreading manure and planting simultaneously can reduce the number of passes over a field. Manage manure to reduce dependence on costly fossil fuel based fertilizers.

Average Fuel Use of Farm Activities in Gallons per Acre*		
Activity	Gasoline	Diesel
Plow 8 inches deep	2.35	1.68
Chisel plow	1.54	1.10
Cultivate field	0.84	0.60
Planting row crops	0.70	0.50
No-till planter	0.49	0.35
Combine	2.24	1.60
Baler	0.63	0.45
Sprayer	0.14	0.10
Grain drying	8.4	6.4

*Estimates from Colorado State University Extension

Grain Drying: In some situations, more energy is used to dry a crop than to grow it. Planting early maturing corn varieties allows for more time to field-dry the crop. When using a moisture meter to ensure dryness of grain, make sure it is reading correctly by comparing the reading with another meter. If mechanical drying is necessary, use a natural air or low temperature drying system.

Buildings: Improve housing facilities by insulating and using natural ventilation when possible to reduce energy needs for heating and cooling. Another way to save energy in buildings is to plant a shelter belt of trees along the north side of buildings to reduce the impact of cold winter winds and therefore reduce heating costs. When

constructing farm buildings place large doorways facing south so as not to lose too much heat during the winter months. An alternative heating source for farm buildings is a waste oil heater that burns used oil from farm machinery. Keep ventilation fans in livestock housing clear of dust so they will run efficiently and last longer. Large diameter fans are more efficient than small ones. Designing buildings to use natural ventilation is the best case scenario because this requires no energy. Compact fluorescent lighting can be installed in barns and in other areas of the farm to reduce the electric bill. For lighting large areas, a high intensity discharge lamp or metal halide lamp is most efficient. Keep in mind that compact fluorescent bulbs used in livestock housing areas must have a covering. Implementing timers, daylight sensors, or motion sensors will insure that lights are only on when they need to be.

Watering Systems: Irrigation and livestock watering systems can be designed to use less energy. Avoid using center-pivot sprinklers because they require a high flow rate of water and a large electric motor to operate. Using evapotranspiration (ET) based irrigation scheduling will result in the appropriate amount of water applied for crop growth. Make sure that livestock waterers are properly insulated and the right size for the number of animals on the farm. Unplug them when the heater is no longer needed.

Electric Fencing: Where appropriate, solar electric fence chargers hooked up to a battery can be used to keep fences charged 24hrs a day, year-round. Like any electric fence, brush and grasses must be mowed so as not to ground the bottom wire.

Other Equipment: Dairy farms have several options for improving the efficiency of refrigeration and vacuum pumps used for milking. One option is the use of a plate cooler which captures heat from milk and transfers it to cold water, partially cooling the milk before it reaches the storage tank. This can reduce cooling time by as much as 15 to 30 minutes, and the warmed water preheats hot water for other uses. A refrigeration heat exchanger is another energy saving device that transfers the excess heat from the milk cooler to preheat water for use in the barn. One more option for use on dairy farms is a variable frequency pump or drive which adjusts the pump’s energy use to meet the milking need, resulting in energy savings of 50-80%. It is recommended that variable frequency drives be used for varying loads such as milk pumps, vacuum pumps and ventilation fans. Consult with an energy auditor before making any new ‘energy saving’ purchases to make sure they will be appropriate for your needs.

Funding Energy Improvements

Improving energy efficiency generally requires minimal investment compared to installing new on-farm energy production systems, therefore many funding opportunities require an audit showing that the farm is currently undertaking energy efficient practices as mentioned in this publication before financing new infrastructure. Since funding opportunities change depending on the political atmosphere, and with your location, be sure to check with an organization such as the Center for Ecological Technology (CET) (cetonline.org) to find out what your farm may qualify for.

Tax Incentives or financial incentives from your local utility company can help offset the costs of installing energy efficient alternatives on your farm.

Summary

Energy conservation and efficiency on farms is a broad topic and farmers will need to find information from other sources regarding the implementation of specific practices. A list of such sources can be found in the 'Additional Information' section of this BMP guide. As a general guideline follow these steps for improving energy efficiency on the farm.

1. Use an energy calculator to determine current energy use on the farm.
2. Conduct an Energy Audit to assess need and viability of energy improvements.
3. Target energy saving projects and practices to implement on the farm.
4. Seek Funding (see above and 'Resources').
5. Implement your energy conservation plan.
6. Make sure to conduct energy audits or perform regular maintenance on machinery to ensure efficient and long lasting performance.

Resources

'25 Quick On-Farm Energy Saving Tips', University of Ontario:
http://www.omafra.gov.on.ca/english/engineer/facts/energy_tips.htm

Massachusetts Farm Energy Program (MFEP)
<http://www.berkshirepioneerrcd.org/mfep/energy.php>

National Sustainable Agriculture Information Service
http://attra.ncat.org/energy_calculators.html

NRCS/USDA Farm Energy Tools
<http://energytools.sc.egov.usda.gov/>

USDA Rural Energy for America Program
<http://www.rurdev.usda.gov/rbs/farmbill/index.html>

U.S. Department of Energy, Energy Efficiency and Renewable Energy (EERE)
<http://apps1.eere.energy.gov>

For more information visit www.umass.edu/cdl

Factsheets in this series were prepared by, Masoud Hashemi, Stephen Herbert, Carrie Chickering-Sears, Sarah Weis, Carlos Gradil, Steve Purdy, Mark Huyler, and Randy Prostack, in collaboration with Jacqui Carlevale.

This publication has been funded in part by the Massachusetts Department of Agricultural Resources and the Massachusetts Farm Bureau Federation, Inc.